

圆锥滚子轴承

d 711.2 ~ 1139.825mm-3806/863.6

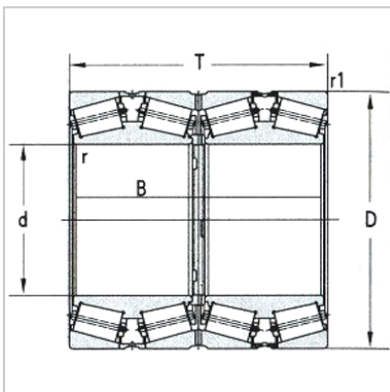
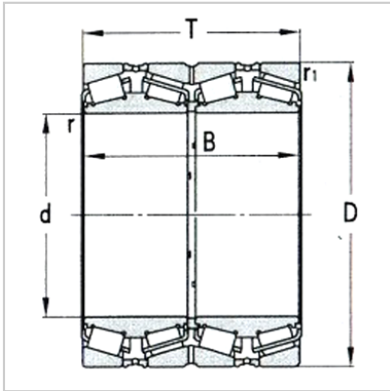

基本尺寸：

dmm :	863.6
din :	34
Dmm :	1169.987
Din :	46.0625
Tmm :	844.55
Tin :	33.25
Bmm :	844.55
Bin :	33.25

倒角尺寸：

rmin(轴向) :	4.8
rmin(径向) :	4.8
r1min(轴向) :	12.7
r1min(径向) :	12.7

基本额定载荷KN：

Cr :	23200
Cor :	76000
轴承代号 :	3806/863.6
重量Kg :	2690

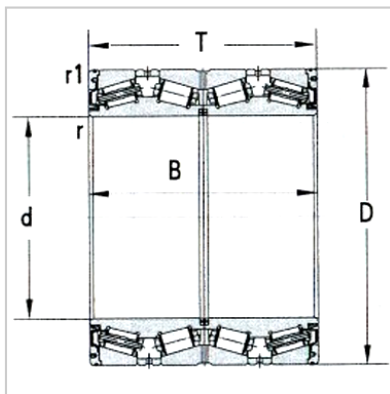
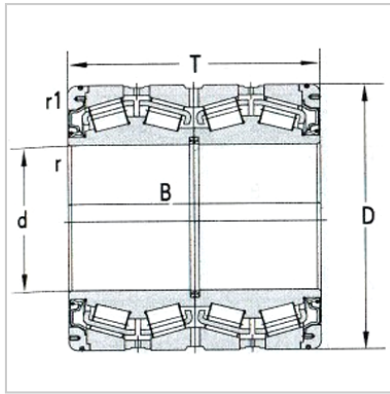

: